

BENNA GRIGLIATA per escavatori

SKELETON BUCKET for excavators

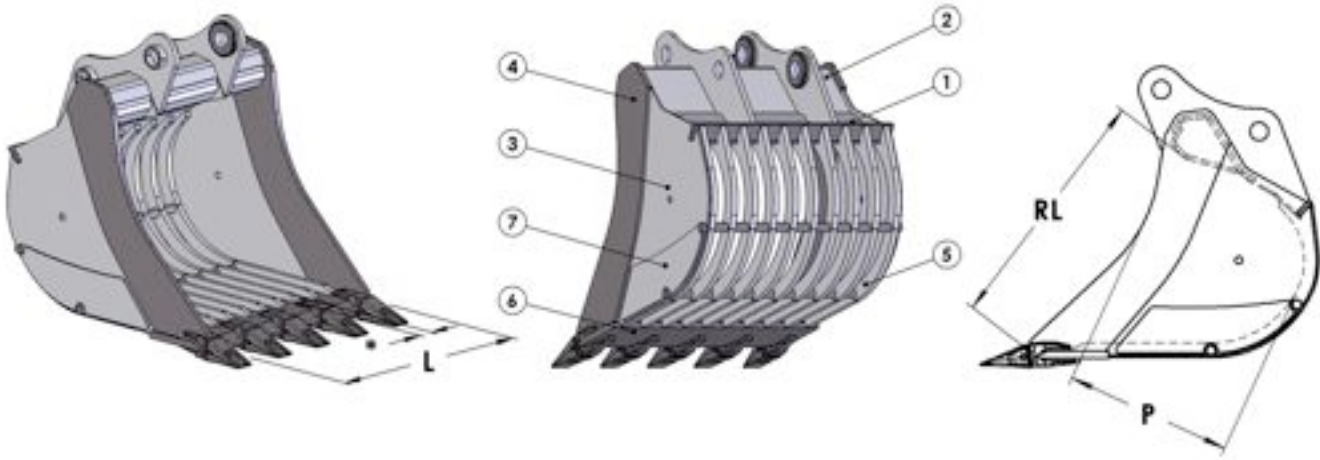

Classe Class	Codice Code	L mm.	Cap. SAE Lt.	Denti Teeth n°	Peso Weight Kg.	RL mm.	P mm.		
								Denti CAT	Esco V29
T.65	T65GR0120	1200	886	5	836	1088	674		
	T65GR0130	1300	974	5	884				
	T65GR0150	1500	1150	6	996				
18-22 ton		1	2	3	4	5	6	/	7
	Materiale Material	Fe510	Fe510	Fe510	Hardox	Fe510	Hb400	/	Fe510
	Spessore Thickness	10 mm	18 mm	8 mm	25 mm	30 mm	35 mm	/	8 mm

Classe Class	Codice Code	L mm.	Cap. SAE Lt.	Denti Teeth n°	Peso Weight Kg.	RL mm.	P mm.		
								Denti CAT	Esco V33
T.66	T66GR0120	1200	1019	5	906	1153	748.5		
	T66GR0130	1300	1120	5	957				
	T66GR0150	1500	1325	6	1075				
22-25 ton		1	2	3	4	5	6	/	7
	Materiale Material	Fe510	Fe510	Fe510	Hardox	Fe510	Hb400	/	Fe510
	Spessore Thickness	10 mm	18 mm	10 mm	25 mm	30 mm	35 mm	/	10 mm

Classe Class	Codice Code	L mm.	Cap. SAE Lt.	Denti Teeth n°	Peso Weight Kg.	RL mm.	P mm.		
								Denti CAT	Esco V33
T.68 25-30 ton	T68GR0120	1200	1266	5	1244	1251	883		
	T68GR0130	1300	1394	5	1309				
	T68GR0150	1500	1650	5	1408				
		1	2	3	4	5	6	/	7
	Materiale Material	Fe510	Fe510	Fe510	Hardox	Fe510	Hardox	/	Fe510
	Spessore Thickness	10 mm	20 mm	10 mm	30 mm	30 mm	40 mm	/	12 mm

Classe Class	Codice Code	L mm.	Cap. SAE Lt.	Denti Teeth n°	Peso Weight Kg.	RL mm.	P mm.		
								Denti CAT	Esco V39
T.70 30-36 ton	T70GR0120	1200	1425	5	1463	1359	921		
	T70GR0130	1300	1553	5	1540				
	T70GR0150	1500	1866	5	1655				
	T70GR0160	1600	2013	6	1762				
		1	2	3	4	5	6	/	7
	Materiale Material	Fe510	Fe510	Fe510	Hardox	Fe510	Hardox	/	Fe510
Spessore Thickness	12 mm	20 mm	12 mm	30 mm	35 mm	40 mm	/	12 mm	

Quotazioni e caratteristiche tecniche disponibili su richiesta per le classi T.75 e T.80

Larghezza intesa su interasse taglienti laterali per le classi T.75 e T.80

* Luce standard griglia-griglia = 80/100 mm.

Quotations and technical details available upon request for T.80 class

Width to be considered on side-knives position for T.75 and T.80 class

** Standard distance grill to grill = 80/100 mm.*