

SERIE PM

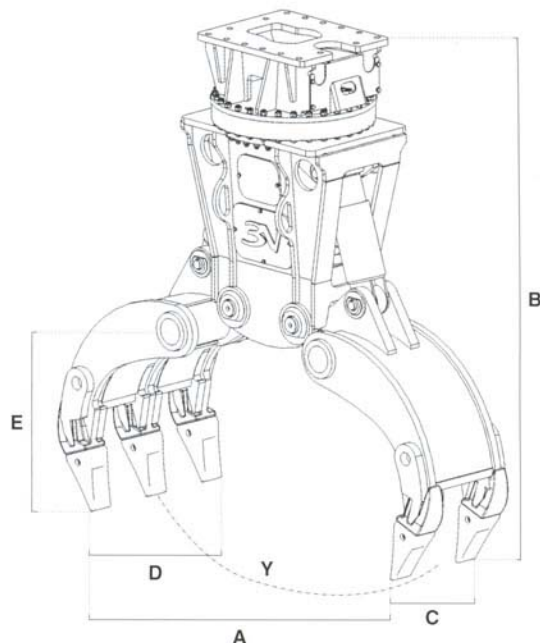

MODEL		PM 15	PM 20	PM 30
	t.	15 : 20	20 : 30	30 : 40
	Kg.	1450	2100	3200
A	mm.	1530	1670	2180
B	mm.	2050	2200	2800
C	mm.	400	520	630
D	mm.	700	800	980
E	mm.	850	900	1100
Y	t.	6	9	15
Cap. SAE	Mc.	0,5	0,8	1,2
	t.	24	35	54
	bar	270	300	300
	MIN l/min.	60	100	120
		H 360°	H 360°	H 360°
	MAX bar	140	140	140
	MAX l/min.	10	10	10
		3/4" gas	1" gas	1" gas

(*) I PESI SOPRA DESCRITTI NON INCLUDONO LA SELLA ATTACCO. CARATTERISTICHE DI PRODOTTO E SPECIFICHE POSSONO VARIARE SENZA OBBLIGO DI PREAVVISO.

(*) THE ABOVE MENTIONED WEIGHTS DO NOT INCLUDE THE EXCAVATOR ATTACHMENT. SPECIFICATIONS ARE SUBJECT TO CHANGE WITHOUT NOTICE.

(*) LOS PESOS INDICADOS NO COMPRENEN EL ENGANCHE EXCAVADORA. LAS CARACTERISTICAS DEL PRODUCTO Y LAS ESPECIFICACIONES PUEDEN VARIAR SIN OBLIGACION DE PREAVISO.

(*) LES POIDS INDIQUÉS NE COMPRENENT PASS L'ATTACHE POUR LA PELLE. LES CARACTÉRISTIQUES ET LES SPÉCIFICATIONS DES PRODUITS PEUVENT ÊTRE MODIFIÉES SANS PRÉVIS.