

BENNA PULIZIA FOSSI MODELLO OLANDA per escavatori

DITCH CLEANING BUCKET HOLLAND PROFILE for excavators

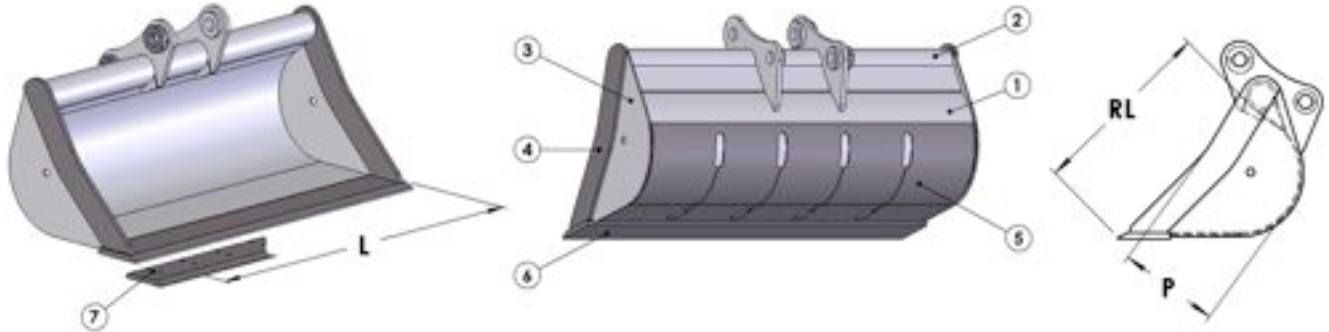

Classe Class	Codice Code	L mm.	Cap. SAE Lt.	Peso Weight Kg.	RL mm.	P mm.			
T.60 16-18 ton	T60PFO150	1500	677	440	900	473			
	T60PFO160	1600	730	465					
	T60PFO180	1800	832	510					
	T60PFO200	2000	935	550					
	T60PFO220	2200	1038	595					
			1	2	3	4	5	6	7 Optional
	Materiale Material	Fe510	Fe510	Fe510	Hardox	Fe510	Hb400	Hb400	
Spessore Thickness	8 mm	14.2 mm	8 mm	20 mm	8 mm	25 mm	250 x 25 mm		

Classe Class	Codice Code	L mm.	Cap. SAE Lt.	Peso Weight Kg.	RL mm.	P mm.		
T.65 18-22 ton	T65PFO160	1600	820	565	956	515		
	T65PFO180	1800	937	617				
	T65PFO200	2000	1054	670				
	T65PFO220	2200	1171	720				
	T65PFO240	2400	1288	770				
	T65PFO250	2500	1346	800				
			1	2	3	4	5	6
Materiale Material	Fe510	Fe510	Fe510	Hardox	Fe510	Hb400	Hb400	
Spessore Thickness	8 mm	16 mm	8 mm	25 mm	8 mm	32 mm	270 x 32 mm	

Classe Class	Codice Code	L mm.	Cap. SAE Lt.	Peso Weight Kg.	RL mm.	P mm.		
T.66 22-25 ton	T66PFO160	1600	930	585	1030	540		
	T66PFO180	1800	1066	640				
	T66PFO200	2000	1200	692				
	T66PFO220	2200	1334	745				
	T66PFO240	2400	1470	797				
	T66PFO250	2500	1535	824				
		1	2	3	4	5	6	7 Optional
	Materiale Material	Fe510	Fe510	Fe510	Hardox	Fe510	Hb400	Hb400
	Spessore Thickness	8 mm	16 mm	8 mm	25 mm	8 mm	32 mm	270 x 32 mm

Classe Class	Codice Code	L mm.	Cap. SAE Lt.	Peso Weight Kg.	RL mm.	P mm.		
T.68 25-30 ton	T68PFO160	1600	1177	810	1155	625		
	T68PFO180	1800	1350	885				
	T68PFO200	2000	1522	960				
	T68PFO220	2200	1694	1035				
	T68PFO240	2400	1867	1110				
	T68PFO250	2500	1953	1147				
		1	2	3	4	5	6	7 Optional
	Materiale Material	Fe510	Fe510	Fe510	Hardox	Fe 510	Hb 400	Hb400
	Spessore Thickness	10 mm	20 mm	10 mm	30 mm	10 mm	35 mm	300 x 35 mm

Classe Class	Codice Code	L mm.	Cap. SAE Lt.	Peso Weight Kg.	RL mm.	P mm.		
T.70 30-36 ton	T70PFO160	1600	1330	855	1240	660		
	T70PFO180	1800	1528	935				
	T70PFO200	2000	1725	1012				
	T70PFO220	2200	1922	1090				
	T70PFO240	2400	2118	1170				
	T70PFO250	2500	2216	1210				
		1	2	3	4	5	6	7 Optional
	Materiale Material	Fe510	Fe510	Fe510	Hardox	Fe 510	Hb 400	Hb400
	Spessore Thickness	10 mm	20 mm	10 mm	30 mm	10 mm	35 mm	300 x 35 mm